

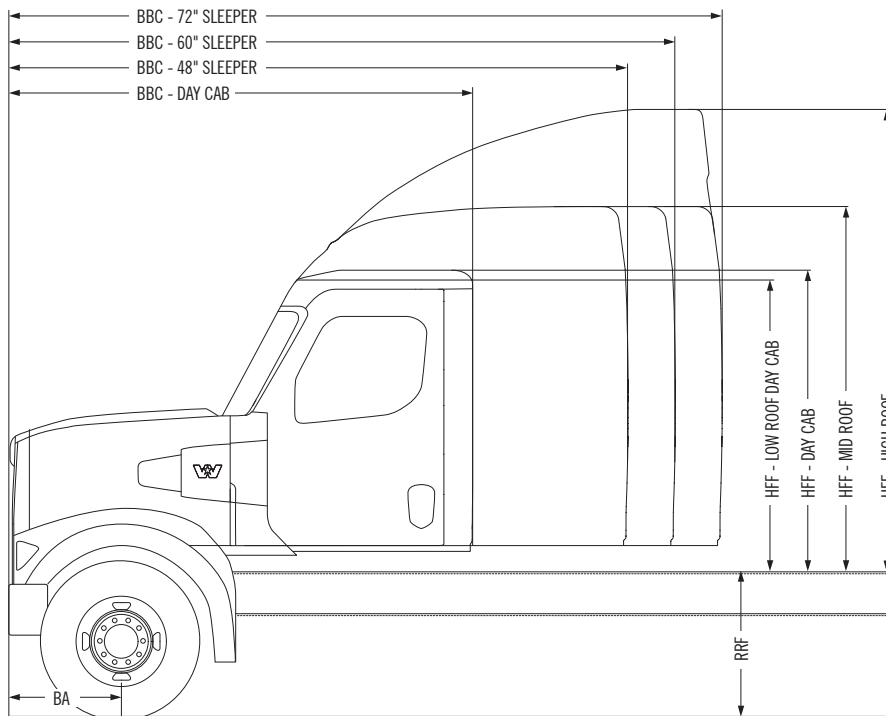

WESTERN STAR 49X



CONFIGURATIONS

STANDARD 6 X 4 SINGLE STEER

GCM

UP TO 140 TONNE GCM*

*HIGHER GCM RATINGS AVAILABLE SUBJECT TO APPLICATION AND ENGINEERING APPROVAL.

| DESCRIPTION | MM |
|--|-------|
| BA - BUMPER TO AXLE | |
| Bumper to axle | 765 |
| BBC - BUMPER TO BACK OF CAB | |
| Day cab | 3,085 |
| 48" sleeper | 4,085 |
| 60" sleeper | 4,385 |
| 72" sleeper | 4,685 |
| RRF - REAR FRAME HEIGHT - UNLADEN | |
| Airliner | 1,056 |
| TuffTrac | 1,084 |
| Primax | 1,072 |
| Neway | 1,072 |
| HFF - HEIGHT FROM FRAME | |
| Day cab standard roof | 1,942 |
| Day cab low trench style roof | 1,903 |
| 60" & 72" mid style roof | 2,360 |
| 72" Stratosphere high roof | 2,985 |
| Mid roof style sleeper air kit | 625 |

> CAB

| | |
|-----|--|
| STD | Steel reinforced Cab w/ aluminium roof 3,085 mm/121" BBC |
| OPT | SLEEPERS 48" mid style roof 60" mid style roof 72" mid style roof 72" Stratosphere high roof Additional roof fairing and side fairings - aerodynamic devices available |

> AIR INTAKE

| | |
|-----|---|
| STD | Dual air intake integrated bonnet system with engine mounted high capacity air cleaner and passive pre-cleaners |
| OPT | Dual air intake through hood mounted snorkles with RAM scoops, engine mounted high capacity air cleaner and dual passive pre-cleaners |

> ENGINE

| | |
|-----|--|
| STD | Detroit DD16 500 hp, 1,850 lb-ft |
| OPT | Detroit DD16 530-600 hp, 1,850-2,050 lb-ft |

> EXHAUST

| | |
|-----|---|
| STD | Horizontal ATS with right hand horizontal tailpipe |
| OPT | Horizontal ATS with dual B-pillar day cab mounted vertical tailpipes Horizontal ATS with dual frame mounted vertical tailpipes |

> TRANSMISSION - AUTOMATED MANUAL

| | |
|-----|---|
| STD | Detroit DT12 OVX 12 speed overdrive 1,850 lb-ft |
| OPT | Detroit DT12 OVX 12 speed overdrive 2,050 lb-ft |

> TRANSMISSION - MANUAL

| | |
|-----|---|
| OPT | Eaton RTLO-20918B 2,050 lb-ft Eaton RTLO-22918B 2,250 lb-ft Eaton AT-1202 A3 auxiliary transmission |
|-----|---|

> FRONT AXLE

| | |
|-----|--|
| STD | Detroit 7.3 t DA-F 3.5" Drop single front axle |
| OPT | Meritor 9 t FL-941 3.5" Drop single front axle |

> FRONT SUSPENSION

| | |
|-----|--|
| STD | Taper leaf springs 7.3 t capacity |
| OPT | Taper leaf springs 8.2 t capacity Taper leaf springs 9.0 t capacity |

> REAR AXLE

| | |
|-----|--|
| STD | Meritor RT46-160GP 20.1 t GAWR tandem |
| OPT | Meritor RT50-160GP 22.7 t GAWR tandem Meritor RT52-185G 23.6 t GAWR tandem Meritor P612 38.1 t GAWR tandem Dana D46-172P 20.1 t GAWR tandem Dana D52-190P 23.6 t GAWR tandem |

> **REAR SUSPENSION**

| | |
|-----|--|
| STD | Airliner 20.9 t GAWR air bag tandem |
| OPT | TufTrac Gen 2 20.9 t - 23.5 t GAWR mechanical tandem TufTrac Gen 2 Comfort Ride 20.9 t - 23.5 t GAWR mechanical tandem Hendrickson Primax EX 20.9 t GAWR tandem Neway ADZ-252 23.5 t GAWR tandem Neway AD-260 27.2 t GAWR tandem |

> **BRAKES**

| | |
|-----|--------------|
| STD | Meritor drum |
| OPT | Bendix disc |

> **UPFIT EFFICIENCY SYSTEMS**

| | |
|-----|---|
| STD | Advanced multiplexed electrical system for easy truck equipment interface: <ul style="list-style-type: none"> • Hard wired dash mounted auxiliary switches |
| OPT | Manufacturer body builder interface, programming and power access Auxiliary in-cab or sleeper mounted e-vault available, which houses: <ul style="list-style-type: none"> • QuickFit programmable controllers • QuickFit interface connectors • TEM-specific power distribution module • High-current power access |

> **SAFETY SYSTEMS**

| | |
|-----|--|
| STD | With Detroit DT12 transmissions Detroit Assurance® Safety Systems including: <ul style="list-style-type: none"> • Active Brake Assist 5 • Adaptive cruise control to 0 kms with adj headway • Side guard assist (OPT) • Lane departure warning • Automatic wipers/headlamps • Intelligent high beam control • Brake hold • Electronic stability control • Anti-lock braking system • Detroit Connect and Virtual Technician platform hardware • Detroit Connect Safety Event Viewer package • Pre-Trip Inspection feature for exterior lamps • Alarm for door open, park brake not set |
| OPT | With manual transmissions all of the above except: <ul style="list-style-type: none"> • Standard adaptive cruise control • No brake hold • Optional lane departure warning • Optional side guard assist |

> **DRIVER INFORMATION MODULE**

| | |
|-----|--|
| STD | Premium instrument cluster with 125 mm TFT colour display |
| OPT | Digital dash displays with 300 mm centre panel cluster and 250 mm B-panel infotainment display |

> **DRIVERS SEATS**

| | |
|-----|--|
| STD | ISRI high back air suspension seat with integrated 3 point seat belt |
| OPT | Rolltek Gen 2 air bag integrated into std ISRI seat ISRI Premium 2.0 high back air suspension seat with swivel base and non-integrated seat belts |

> **PASSENGER SEATS**

| | |
|-----|---|
| STD | Sears tool box high back non suspension seat |
| OPT | ISRI high back air suspension seat with integrated 3 point seat belt ISRI Premium 2.0 high back air suspension seat with swivel base and non-integrated seat belts Battery box mid back non suspension seat |

> **WHEELS**

| | |
|-----|--|
| STD | Steel disc 10 stud |
| OPT | Aluminium disc 10 stud Standard, polished or Dura-Bright wheel finish available on Aluminium wheels |

> **FUEL/HYDRAULIC & COMBINATION TANKS**

| | |
|-----|---|
| STD | Round 635 mm diameter 302 L to 567 L* Square (LCS) 735 mm x 700 mm 320 L to 775 L *Various split/Combos available |
|-----|---|

> **PAINT**

| | |
|-----|--|
| STD | Single colour cab and single colour chassis |
| OPT | Up to 4 colours. Base coat/Clearcoat solid colour, metallic or pearl |



No matter where you are, we can get you going – 24 hour road assistance.

1800 247 WSTAR
1800 247 97827