

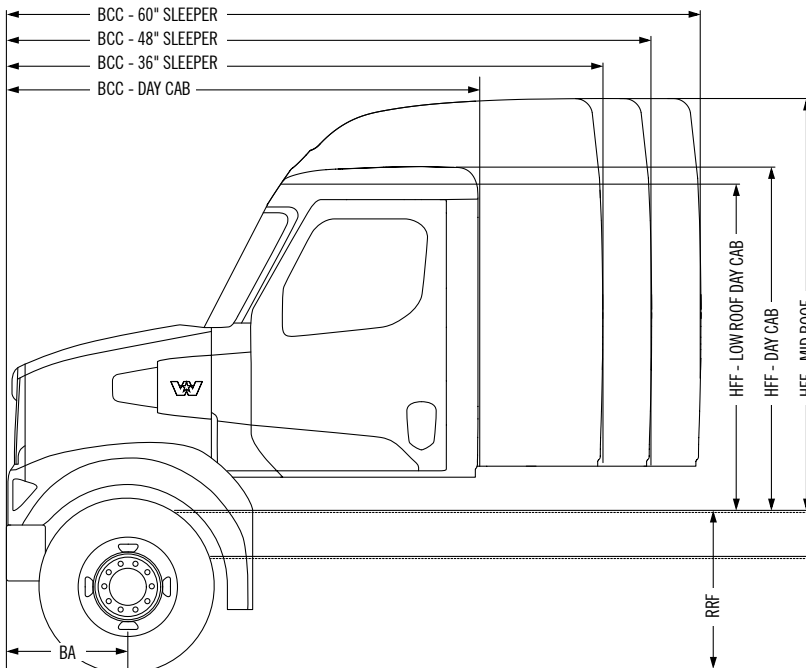

WESTERN STAR 48X



CONFIGURATIONS

STANDARD 6 X 4 SINGLE STEER

GCM

UP TO 130 TONNE GCM*

*HIGHER GCM RATINGS AVAILABLE SUBJECT TO APPLICATION AND ENGINEERING APPROVAL.

DESCRIPTION MM

BA - BUMPER TO AXLE

Bumper to axle 765

BBC - BUMPER TO BACK OF CAB

Day cab 2,865

36" sleeper 3,565

48" sleeper 3,865

60" sleeper 4,165

RRF - REAR FRAME HEIGHT - UNLADEN

Airliner 1,056

TufTrac 1,084

Primax 1,072

Neway 1,072

HFF - HEIGHT FROM FRAME

Day cab standard roof 2,042

Day cab low trench style roof 2,003

36" low trench style roof 2,012

36", 48" & 60" mid style roof 2,460

Mid roof style sleeper air kit 625

➤ **CAB**

STD Steel reinforced day cab w/- aluminium roof
2,865 mm/112.8" BBC

OPT Low trench style roof steel reinforced day cab w/- composite roof

OPT **SLEEPERS**
36" low trench style roof
36" mid style roof
48" mid style roof
60" mid style roof
Additional roof fairing and side fairings - aerodynamic devices available

➤ **AIR INTAKE**

STD Side of bonnet air intake with engine mounted high capacity air cleaner and passive pre-cleaner

OPT Dual air intake through hood mounted snorkles with RAM scoops, engine mounted high capacity air cleaner and dual passive pre-cleaners

➤ **ENGINE**

STD Detroit DD13 Gen 5 450 hp, 1,550 lb-ft

OPT Detroit DD13 Gen 5 470-525 hp, 1,650-1,850 lb-ft
Detroit DD16 500-600 hp, 1,850-2,050 lb-ft

➤ **DETROIT WARRANTY COVERAGE**

STD 4 years / 400,000 L / 12,000 hrs & 805,000 kms

OPT 4 years / 500,000 L / 15,000 hrs & 805,000 kms
5 years / 500,000 L / 15,000 hrs & 1,046,500 kms
5 years / 600,000 L / 15,000 hrs & 1,046,500 kms

➤ **EXHAUST**

STD Horizontal ATS with LH B-pillar mounted vertical tailpipe

OPT Horizontal ATS with right hand horizontal tailpipe
Horizontal ATS with dual cab mounted vertical tailpipes
Horizontal ATS with dual frame mounted vertical tailpipes

➤ **TRANSMISSION - AUTOMATED MANUAL**

STD Detroit DT12 OV 12 speed overdrive 1,550 lb-ft

OPT Detroit DT12 OV 12 speed overdrive 1,650 lb-ft to 1,850 lb-ft
Detroit DT12 OVX 12 speed overdrive 1,850 lb-ft to 2,050 lb-ft

➤ **TRANSMISSION - MANUAL**

OPT Eaton RTLO-16918B 1,650 lb-ft
Eaton RTLO-18918B 1,850 lb-ft
Eaton RTLO-20918B 2,050 lb-ft
Eaton RTLO-22918B 2,250 lb-ft

➤ **FRONT AXLE**

STD Meritor 6.6 t FG941 3.5" drop single front axle

OPT Detroit 7.3 t DA-F 3.5" drop single front axle

➤ **FRONT SUSPENSION**

STD Taper leaf springs 6.6 t capacity - FG941

OPT Taper leaf springs 7.3 t capacity - Detroit DA-F

SPECIFICATIONS



> REAR AXLE

STD	Meritor MX-40-14XGP 18.1 t GAWR tandem
OPT	Meritor MX44-14XGP 19.9 t GAWR tandem Meritor RT46-160GP 20.1 t GAWR tandem Meritor RT50-160GP 22.7 t GAWR tandem Meritor RT52-185G 23.6 t GAWR tandem Dana D46-172P 20.1 GAWR tandem

> REAR SUSPENSION

STD	Airliner 20.9 t GAWR air bag tandem
OPT	Airliner 18.1 t GAWR air bag tandem TufTrac Gen 2 18.1 t - 23.5 t GAWR mechanical tandem TufTrac Gen 2 Comfort Ride 18.1 t - 20.9 t GAWR mechanical tandem Hendrickson Primax EX 20.9 t GAWR air bag tandem Neway ADZ-252 23.5 t GAWR air bag tandem Neway AD-260 27.2 t GAWR air bag tandem

> BRAKES

STD	Bendix disc
OPT	Meritor drum

> UPFIT EFFICIENCY SYSTEMS

STD	Advanced multiplexed electrical system for easy truck equipment interface: <ul style="list-style-type: none">• Hard wired dash mounted auxiliary switches
OPT	Manufacturer body builder interface, programming and power access Auxiliary in-cab or sleeper mounted e-vault available, which houses: <ul style="list-style-type: none">• QuickFit programmable controllers• QuickFit interface connectors• TEM-specific power distribution module• High-current power access

> WHEELS

STD	Aluminium disc 10 stud
OPT	Steel disc 10 stud Standard, polished or Dura-Bright wheel finish available on Aluminium wheels

> FUEL/HYDRAULIC & COMBINATION TANKS

STD	Round 635 mm diameter 227 L to 567 L* Square (LCS) 735 mm x 700 mm 320 L to 775 L *Various fuel and hydraulic tank combinations available
-----	---

> DRIVER INFORMATION MODULE

STD	Premium instrument cluster with 125 mm TFT colour display
OPT	Digital dash displays with 300 mm centre panel cluster and 250 mm B-panel infotainment display

> SAFETY SYSTEMS

STD	With Detroit DT12 transmissions: Detroit Assurance® Safety Systems including: <ul style="list-style-type: none">• Active Brake Assist 5• Adaptive cruise control to 0 kms with adj headway• Side guard assist (OPT)• Lane departure warning• Automatic wipers/headlamps• Intelligent high beam control• Brake hold• Electronic stability control• Anti-lock braking system• Detroit Connect and Virtual Technician platform hardware• Detroit Connect Safety Event Viewer package• Pre-Trip Inspection feature for exterior lamps• Alarm for door open, park brake not set
OPT	With manual transmissions all of the above except: <ul style="list-style-type: none">• Standard (adaptive) cruise control• No brake hold• Optional lane departure warning• Optional side guard assist

> DRIVERS SEATS

STD	ISRI high back air suspension seat with integrated 3 point seat belt
OPT	Rolltek Gen 2 air bag integrated into std ISRI seat ISRI Premium 2.0 high back air suspension seat with swivel base and non-integrated seat belts

> PASSENGER SEATS

STD	Sears tool box high back non suspension seat
OPT	ISRI high back air suspension seat with integrated 3 point seat belt ISRI Premium 2.0 high back air suspension seat with swivel base and non-integrated seat belts Battery box mid back non suspension seat

> PAINT

STD	Single colour cab and single colour chassis Cab - one colour basecoat/clearcoat, Chassis - one colour basecoat/clearcoat
OPT	Up to 4 colours. Base coat/Clearcoat solid colour, metallic or pearl

STAR ASSIST™

No matter where you are, we can get you going – 24 hour road assistance.

1800 247 WSTAR
1800 247 97827