



**WESTERN STAR TRUCKS**



**X-SERIES**



**47X**

**48X**

**49X**



# SIMPLY THE BEST TRUCKS

**WE'VE EVER BUILT.**

Western Star trucks have always been built to deliver more. More durability, more dependability, and more value for Australian drivers. And the X-Series takes that commitment even further. Whether it's on the highway hauling a road train, or on a work site, our trucks get the job done.

Winner of the highly-prestigious Truck of The Year Australasia (ToYA) award for 2024, the X-Series is the most-tested Western Star ever.

Proudly distributed by Penske Australia, the X-Series boasts **superior comfort**, an **advanced safety package**, a **powerful integrated driveline**, and our **legendary Star durability** – even in the most rugged applications.

Seriously modern and backed by Penske's powerful commitment, the X-Series is the best decision you'll make.

Western Star Trucks. Serious Trucks.

➤ **BUILT WITH ONE GOAL IN MIND**

More than half a decade was dedicated to designing and engineering our X-Series line-up of trucks to produce the best trucks on the market. To achieve this, our Stars had to meet the benchmarks Western Star Trucks established at the start of the X-Series project. And then Western Star put them to the test to ensure they delivered.

TESTING



CAB INTEGRITY TEST



TECHNICAL EXCELLENCE

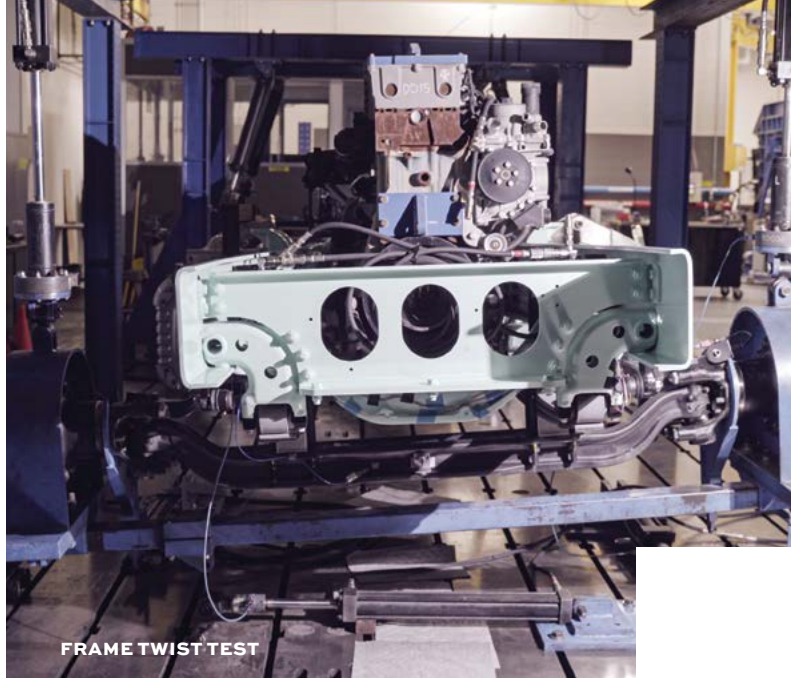

FRAME TWIST TEST



CAB CRUSH TEST



DESIGNED AND ENGINEERED FOR AUSTRALIAN CONDITIONS



SHAKE TEST



VARIOUS APPLICATIONS

# PROVEN.

**LIKE NO OTHER.**

The Western Star 47X, 48X, and 49X have been tested like no other Western Star before. Built from the ground up, a selection of parts unique to the X-Series were specifically developed to survive the challenges of the Australian market, and matched with cutting-edge technology to make that performance even better. Then Western Star tested them – every nut, bolt, and component to simulate 15 years of use. In the end, every component exceeded our already demanding standards.

Because a Western Star truck has to pass our tests before you can put it to yours.

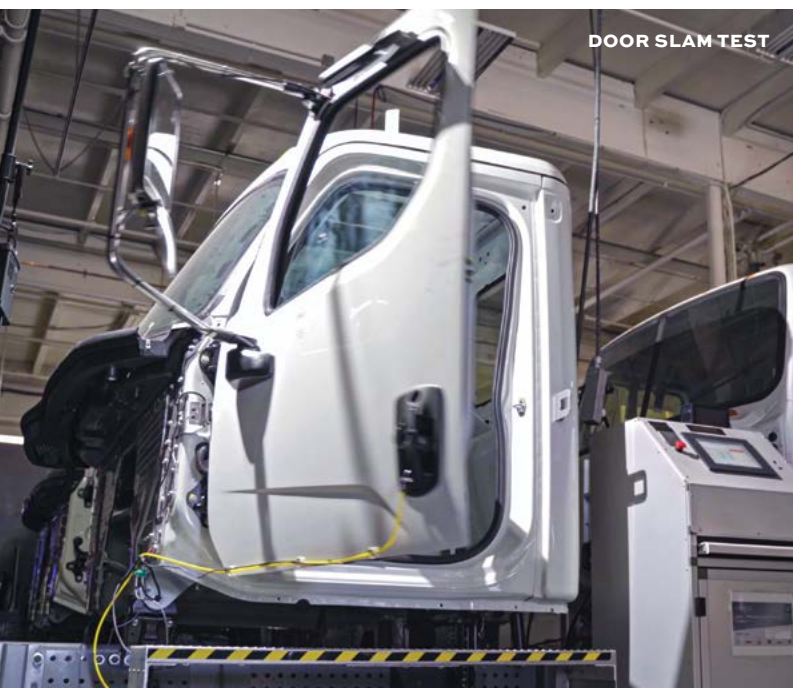

DOOR SLAM TEST

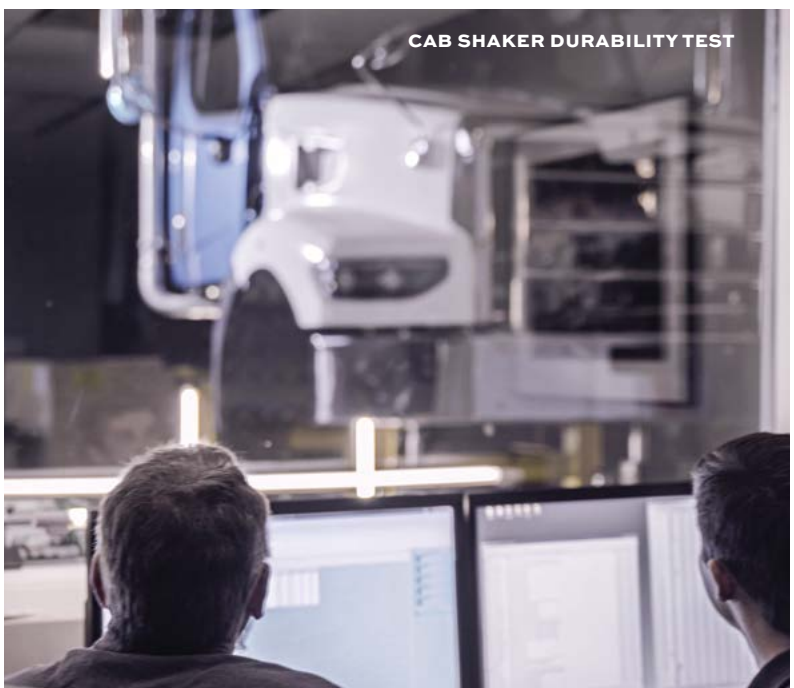

CAB SHAKER DURABILITY TEST



MADRAS DURABILITY TRACK



TESTED IN AND FOR AUSTRALIA

The Western Star toolkit just got more versatile

# GETTING THE JOB DONE

## IS NOW THREE TIMES AS EASY.

When you need a seriously tough truck, Western Star has always been the only choice. And with the X-Series trucks, the toughness Western Star has always been known for, is taken to the next level. The 47X, 48X, and 49X are engineered from the ground up to deliver decades of dependable performance.

With a short, sloped bonnet that yields payload flexibility, a set-back front axle, and choice of power with either the Detroit DD13 or the Cummins L9, the **47X** is highly versatile.

The **48X** is the perfect partner for any application. Featuring a set-forward front axle, powered by a Detroit DD13 or DD16 engine, and with a BBC of 2,865 mm, the 48X boasts up to 600 hp and 2,050 lb-ft of torque.

The toughest of the tough, the **49X** has up to 200+ tonnes GCM capability and is available with multiple cabin options including the class-leading 72" Stratosphere sleeper cab making it the ultimate home away from home.



47X SPECIFICATIONS	48X SPECIFICATIONS	49X SPECIFICATIONS
<b>ENGINE MODELS</b> Cummins L9 and Detroit DD13 Gen 5	<b>ENGINE MODELS</b> Detroit DD13 Gen 5 and Detroit DD16	<b>ENGINE MODELS</b> Detroit DD16
<b>HORSEPOWER &amp; TORQUE</b> 330-380 hp & 1,000-1,250 lb-ft 450-525 hp & 1,550-1,850 lb-ft	<b>HORSEPOWER &amp; TORQUE</b> 450-525 hp & 1550-1850 lb-ft 500-600 hp & 1,850-2,050 lb-ft	<b>HORSEPOWER &amp; TORQUE</b> 500-600 hp & 1,850-2,050 lb-ft
<b>AXLE CONFIGURATIONS</b> 6x4, 8x4*, 10x4*	<b>AXLE CONFIGURATIONS</b> 6x4	<b>AXLE CONFIGURATIONS</b> 6x4
<b>BUMPER TO BACK OF CAB</b> 2,835 mm / 111.6"	<b>BUMPER TO BACK OF CAB</b> 2,865 mm / 112.8"	<b>BUMPER TO BACK OF CAB</b> 3,085 mm / 121.5"
<b>AVAILABLE CABINS</b> Day cab – low trench style roof Day cab – standard roof 36" sleeper – low trench style roof 36" sleeper – mid style roof 48" sleeper – mid style roof	<b>AVAILABLE CABINS</b> Day cab – low trench style roof Day cab – standard roof 36" sleeper – low trench style roof 36" sleeper – mid style roof 48" sleeper – mid style roof 60" sleeper – mid style roof	<b>AVAILABLE CABINS</b> Day cab – low trench style roof Day cab – standard roof 48" sleeper – mid style roof 60" sleeper – mid style roof 72" sleeper – mid style roof 72" sleeper – Stratosphere high roof

\*Conditions apply

LEGENDARY DURABILITY

Heavy-duty X-Series chassis



# LEGENDARY DURABILITY.

Underpinned by a long-standing North American heritage, the custom-built X-Series exudes legendary durability. With durable stainless steel and aluminium bright works, high air intakes, and a high-efficiency radiator cooling package, the X-Series is the strongest and most tested Western Star cab and chassis ever!

Heavy-duty X-Series chassis

# ALWAYS BUILD

## ON A STRONG FOUNDATION.

Featuring a robust heavy-duty frame, the X-Series is engineered and built from the ground up to meet the demands of severe applications while still being lighter, more durable, easier to service, and extremely body builder friendly.

That means that from the start, you'll have a truck that can handle more payload and deliver greater uptime for improved profitability.

### FRAME HEIGHTS

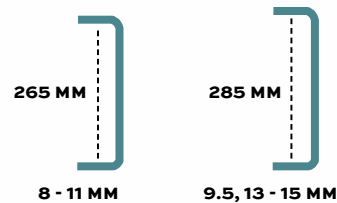

FRAME	RBM (MILLION INCH-LBS)
8 MM	1.8
9 MM	2.0
9.5 MM	2.5
11 MM	2.5
13 MM	3.3
15 MM	3.8
13 MM WITH 6 MM REINFORCEMENT	4.5
15 MM WITH 9 MM REINFORCEMENT	5.6

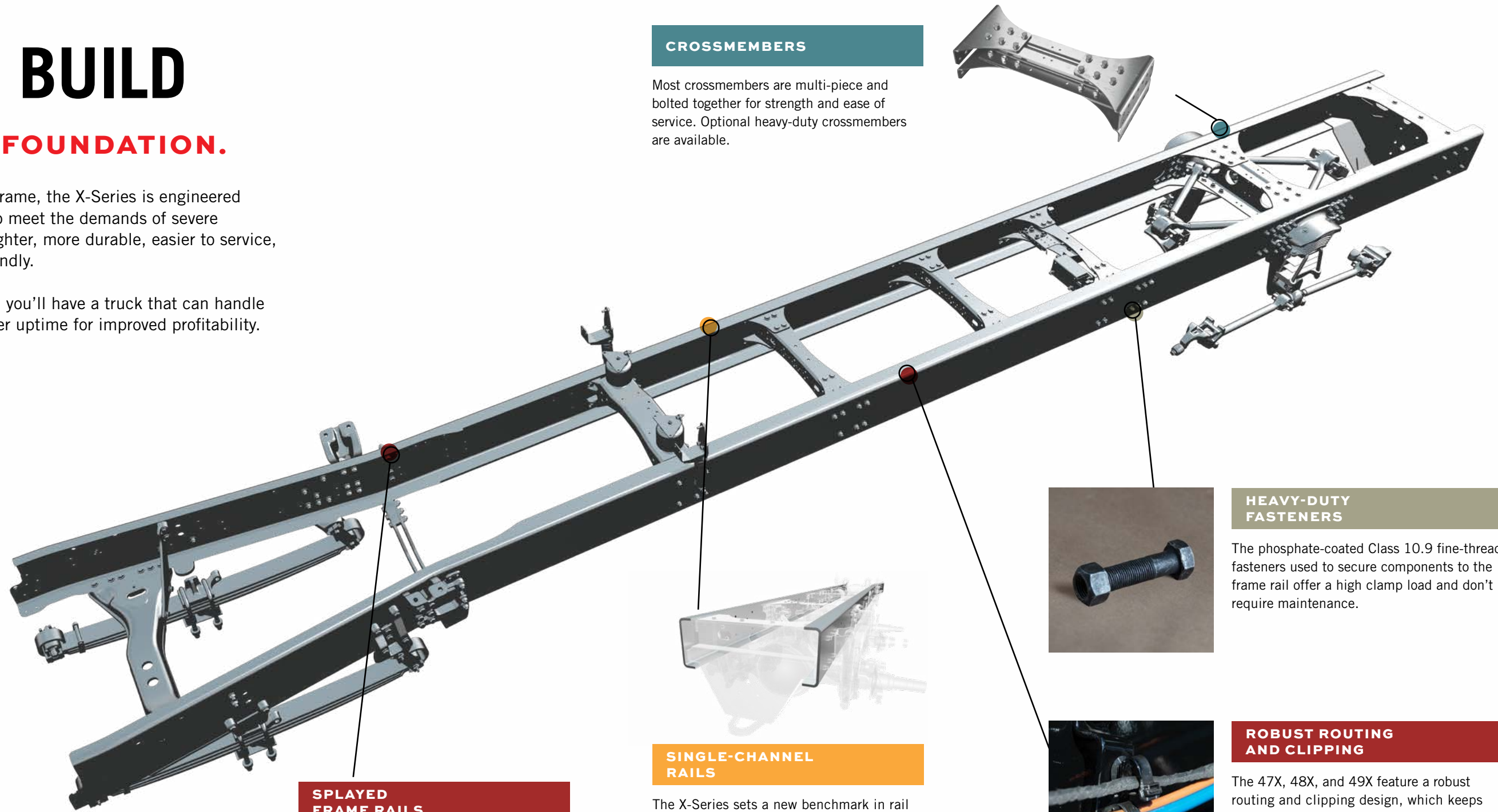

### CROSSMEMBERS

Most crossmembers are multi-piece and bolted together for strength and ease of service. Optional heavy-duty crossmembers are available.

### SPLAYED FRAME RAILS

Splayed frame shape at the front of the chassis allows for engine and radiator packaging in addition to improving serviceability.

### SINGLE-CHANNEL RAILS

The X-Series sets a new benchmark in rail performance. Its pioneering high-strength single-channel rail delivers an impressive 3.8 million RBM without an insert, while the advanced 9.5 mm rail achieves the same RBM rating as a traditional 11 mm rail at a fraction of the weight. Standing 285 mm tall, the X-Series design trims nearly 45 kg compared to the 11 mm option, all without compromising strength or durability.

### HEAVY-DUTY FASTENERS

The phosphate-coated Class 10.9 fine-thread fasteners used to secure components to the frame rail offer a high clamp load and don't require maintenance.

### ROBUST ROUTING AND CLIPPING

The 47X, 48X, and 49X feature a robust routing and clipping design, which keeps air lines and wiring harnesses away from the frame, decreasing chafing and debris build-up for reduced corrosion. Heavy-duty body builder routing and clipping options are available for more complex upfits, allowing additional space to separate and route air lines, harness bundles, and more.

Steel-reinforced cab that is lighter, safer, stronger

# THE EVOLUTION OF TOUGH.

## THE X-SERIES CAB.

Western Star has always set the standard for building some of the toughest and safest cabs around. We continue that tradition with our X-Series cab. The X-Series cab is engineered to handle the toughest jobs in the most unforgiving environments. Constructed from aluminium and enhanced with steel reinforcements, this cab is lighter, safer, stronger, and more spacious than any Western Star cab before. All of which adds up to a cab that is designed to protect and retain drivers while delivering greater payload and uptime.



### THE X-SERIES DOOR

Designed as an integral part of the steel-reinforced aluminium cab structure, the X-Series door is crafted from rugged steel using state-of-the-art tooling to ensure unmatched fit and finish, then galvanised and hem-sealed for complete corrosion resistance. The door is integrated with the cab utilising forged steel hinges, which were slam tested to simulate 15 years of use so you know it will survive even your toughest days on the toughest job sites.

**STRUCTURAL OPTIMISATION**

Western Star engineers used state-of-the-art topology optimisation technology to place structural material and reinforcements strategically to minimise weight while maximising toughness and safety.

- > Backwall header reinforcement
- > Increased A-pillar section size and strength
- > B-pillar reinforcement
- > Hinge reinforcements
- > Quiet Steel engine tunnel
- > Cab floor reinforcement

**OPTIONAL LOW TRENCH STYLE ROOF**

Optional composite roof with a lowered centre section enables optimised packaging of over-cab equipment, giving you a purpose-built vehicle that minimises overall vehicle height while maximising interior headroom and door openings.

**CAB MOUNT SYSTEM**

The X-Series cab mount system features cab isolators designed to reduce driver fatigue by providing optimal cab stability, helping deliver the incredibly comfortable ride for which Western Star is renowned.

**ENGINE TUNNEL**

Quiet Steel engine tunnel reduces engine noise intrusion into the cab to provide a premium operating environment.

## LEGENDARY DURABILITY

Steel-reinforced cab that is lighter, safer, stronger



# BUILT FOR ONE JOB. YOURS.

48X with 36" mid style roof walk through sleeper, roof fairing and 300 mm extenders shown.

### 48X 48" CAB



### 48X DAY CAB

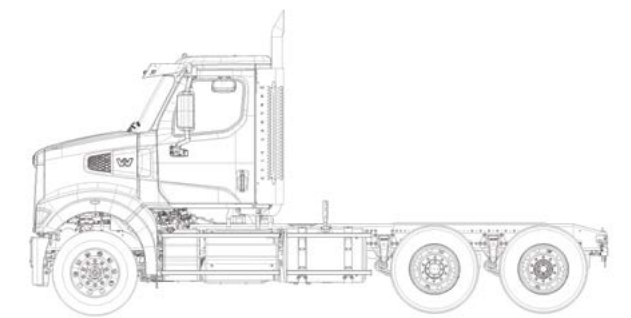

### TANKS

#### FUEL TANKS

Round aluminium 25" diameter, 227-567 litres  
LCS square aluminium, 360-775 litres

#### DEF TANKS

30, 49, 87, and 200 litres  
Mounted in a forward position on the left-hand side,  
regardless of size

### EXHAUST OPTIONS

Single right-hand cab-mounted vertical exhaust  
Dual cab-mounted vertical exhaust (day cabin)  
Dual frame-mounted vertical exhaust (sleeper cabin)  
Right-hand outboard under-step-mounted horizontal  
aftertreatment system with horizontal exhaust

### AXLES CONFIGURATIONS

#### STEER AXLES

Detroit and Meritor – 6.6 t to 9 t GAWR  
Note: Twin steer available in 47X

#### REAR DRIVE AXLES

Meritor and Dana  
Tandem – 18.1 t to 23.6 t GAWR

### REAR SUSPENSIONS

AirLiner 18.1 t to 20.9 t GAWR tandem  
Neway ADZ and AD 23.5 t to 27.2 t  
TufTrac Gen2 and comfort ride 18.1 to 23.6 t GAWR tandem  
Hendrickson Primaax EX 20.9 t GAWR  
Hendrickson Ultimaax 23.6 t GAWR tandem

LEGENDARY DURABILITY

Tough by design

**DURABLE, LONG-LASTING  
ALL METAL BRIGHTWORK**

- Intake covers
- Grille
- Grille surround
- Sun visor
- Mirror backs

**DUAL STAINLESS STEEL  
AIR INTAKE COVERS**

**EASY-ACCESS,  
GLOVE-FRIENDLY  
BONNET LATCHES**

**BONNET  
REINFORCEMENTS FOR  
AUXILIARY MIRRORS**

**DOUBLE-LAYERED,  
IMPACT-RESISTANT  
FENDERS**

**STAINLESS STEEL  
RADIATOR-MOUNTED  
GRILLE**

**ROBUST ALUMINIUM  
RADIATOR**

**STRUT-ASSISTED  
BONNET OPENING AND  
CLOSING WITH  
STANDARD SAFETY LOCK**

# STRONGER. LIGHTER.

## BETTER. THAN EVER.

Engineered to improve durability and performance, our bonnets also provide superior visibility for drivers. They are incredibly strong, thanks to new moulded resin material that's robotically sealed and bonded together for precision-manufactured quality and durability. And each bonnet is approximately 45 kg lighter than legacy product bonnets, and is designed to resist high impacts to last the life of the vehicle.

**BONNET OPENING  
ASSIST STRUT**

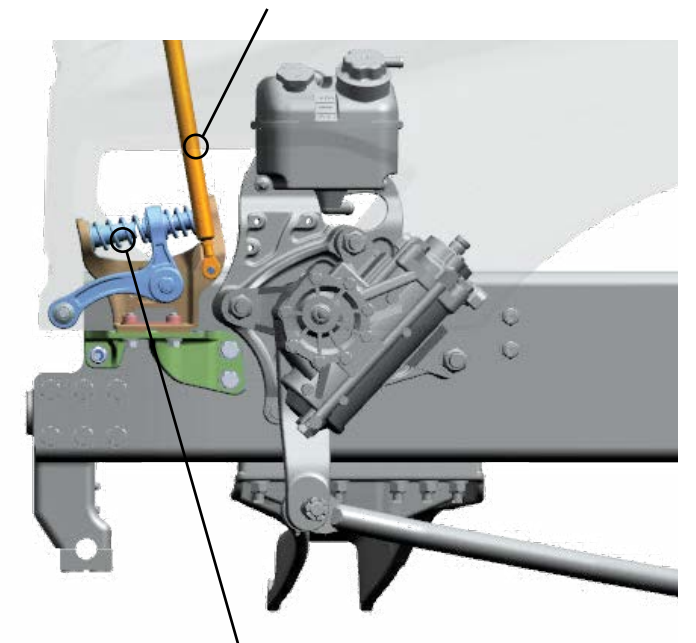

**ROBUST ISO TECH BONNET  
SUSPENSION SYSTEM**

The Western Star-exclusive ISO Tech bonnet suspension system is purpose-built to isolate the bonnet from even the most brutal road conditions.



# PUT THE POWER

## OF DATA TO WORK.

The 47X, 48X, and 49X ensure advanced productivity with the Detroit Connect suite of connected vehicle services, which translates vehicle performance data into real-time information you can use to keep your trucks on the job site and out of the shop.



### DETROIT CONNECT VIRTUAL TECHNICIAN

Standard on all Detroit engines, Virtual Technician remote diagnostic service on the X-Series helps increase uptime. If the truck experiences a fault, Virtual Technician sends you an alert, notifying you of the severity of the fault and how to fix it. It's like having a team of experts from Detroit at your fingertips, working to keep your trucks on the job.

### DETROIT CONNECT PORTAL

The Detroit Connect Portal gives you real-time truck data to make informed decisions about service, helping reduce downtime. This powerful tool offers a holistic view of your vehicle's fault codes and allows you to track fleet trends, giving you the power to plan for scheduled service.

LEARN MORE ABOUT  
DETROIT CONNECT AT

[DETROITANZ.COM](https://DETROITANZ.COM)

POWERFUL INTEGRATED DRIVELINE

*Components with a long history of performance*



# POWERFUL INTEGRATED DRIVELINE.

Featuring high-performing tried and tested Detroit and Cummins\* engine options and Detroit DT12, Allison fully automatic, and Eaton Fuller manual transmission options, the X-Series boasts a powerful integrated driveline that ticks the boxes in any application.

\*Cummins engine is available in 47X 8x4 only

Components with a long history of performance

# THE POWER

## TO GET ANY JOB DONE.

Give your X-Series truck added toughness and dependability with Detroit and Cummins engine options and Detroit, Eaton Fuller, and Allison transmission choices.

- > The Detroit **DD13 Gen 5** is designed with the best in cutting-edge diesel engine technology and engineering for increases in power, durability, and productivity. It delivers 450 to 525 hp, 1,500 to 1,850 lb-ft of torque, and is GHG-24 compliant.
- > The most powerful on-highway engine ever built by Detroit, the **DD16** delivers up to 500 to 600 hp, 1,850 to 2,050 lb-ft of torque, and is GHG-24 compliant.
- > The Cummins **L9** is available in the 47X 8x4 and produces 330 to 380 hp, 1,050 to 1,250 lb-ft of torque, and is EPA-21 compliant.

### ENGINES



**47X\***  
**CUMMINS**  
**L9**  
**HORSEPOWER**  
Up to 380 hp  
**TORQUE**  
Up to 1,250 lb-ft

\*8x4 only



**47X / 48X**  
**DETROIT**  
**DD13 GEN 5**  
**HORSEPOWER**  
Up to 525 hp  
**TORQUE**  
Up to 1,850 lb-ft



**48X / 49X**  
**DETROIT**  
**DD16**  
**HORSEPOWER**  
Up to 600 hp  
**TORQUE**  
Up to 2,050 lb-ft

### TRANSMISSIONS

To spec the exact transmission you need, see your nearest Western Star dealer.

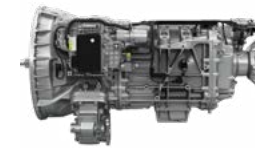

**47X / 48X / 49X**  
**DT12-OV**  
Automated Manual  
**TORQUE**  
2,250 lb-ft  
**GCM**  
72,500 kg  
**REAR PTO**  
Yes  
**SIDE PTO**  
Yes

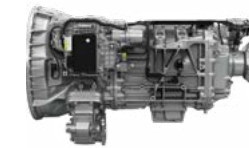

**47X / 48X / 49X**  
**DT12-OVX**  
Automated Manual Extreme  
**TORQUE**  
2,500 lb-ft  
**GCM**  
90,000 kg\*  
**REAR PTO**  
Yes  
**SIDE PTO**  
Yes

\*Application approval required.



**47X / 48X / 49X**  
**EATON FULLER**  
Manual  
**TORQUE**  
1,650-2,250 lb-ft  
**REAR PTO**  
Yes  
**SIDE PTO**  
Yes



**47X†**  
**ALLISON**  
Automatic  
**TORQUE**  
1,650-1,850 lb-ft  
**GCM†**  
77,110 kg\*  
**REAR PTO**  
Yes  
**SIDE PTO**  
Yes

### DETROIT DT12 X-SERIES

The DT12 X-Series range of automated manual transmissions has been specially engineered and rigorously tested for the unique needs of heavy-duty trucks. Well-proven Detroit quality is combined with cutting-edge technology and durable components like large, robust gearing for even greater dependability. And you'll find this rugged performance in two models – the DT12-OV and DT12-OVX – that boast X-Series features including:

- > Rock-free mode allows the truck to free itself from wheel-stuck situations\*
- > Off-road mode enables smooth driving on extreme terrain\*

\*Application dependent  
† 8x4 only

Safe by design



# ADVANCED SAFETY.

Delivering an advanced safety package that is unbeatable, the X-Series boasts Active Brake Assist 5, lane departure warning, side guard assist, tailgate warning, and much more. Furthermore, an improved visibility package and the innovative RollTek seat with rollover restraint and airbag give drivers ultimate peace of mind.

49X with 72" Stratosphere high roof walk through sleeper depicted.



48X with 36" walk through integrated sleeper with aerodynamic fairing depicted.

Safe by design

# THESE TRUCKS HAVE THE SMARTS TO KEEP YOU SAFE

Technology gets tough in the X-Series, the first Western Star trucks to offer the Detroit Assurance suite of safety systems. From remote logging sites to urban construction sites, Detroit Assurance improves safety there and back.

## SIDE GUARD ASSIST

A game changer for safety, optional side guard assist detects objects in the passenger side blind spot and alerts the driver.



## FEATURES OF DETROIT ASSURANCE

### ACTIVE BRAKE ASSIST (ABA) 5

Active brake assist detects distance and speed to moving and stationary objects in its path and determines if braking is necessary. It's the only system on the market that works down to 8 km/h, making it ideal for travel in congested urban areas. It also recognises pedestrians who are about to cross in the truck's path, alerting the driver while partially braking, followed by full braking if the driver does not react. The market-leading ABA 5 has fused a camera and radar, which is cutting-edge technology.



### ADAPTIVE CRUISE CONTROL AND BRAKE HOLD MODE\*

Detroit Assurance enables state-of-the-art features that make a driver's workday safer and more comfortable than ever before. And on the job site, brake hold mode keeps a truck stopped when the driver removes their foot from the brake pedal, or if their foot unintentionally slips off.

- > LANE DEPARTURE WARNING
- > TAILGATE WARNING
- > ACTIVE SPEED INTERVENTION
- > AUTOMATIC HEADLIGHTS/WIPERS†
- > INTELLIGENT HIGH-BEAMS†

\*Standard adaptive cruise control available with DT12 OV / DT12 OVX transmission. T&Cs apply.  
†Specification dependent.

Safe by design

# SAFETY

## THAT IS EASY TO SEE.

### INTELLIGENT LED HEADLIGHTS

The best headlights Western Star has ever produced, the dual stage intelligent LED headlights are designed to last the lifetime of the truck, with no bulbs needing replacement. Plus, they deliver superior visibility and improved safety with:

- > Integrated amber daytime running lights to make the truck more visible to oncoming traffic and on the job site
- > LED output designed to fully illuminate the road and job site, including off to the sides of the vehicle, to reduce eye fatigue while letting drivers detect objects sooner
- > High-impact polycarbonate lenses with additional hard coating protection to prevent cracking, scratching, or damage to the headlight from road or job site debris



### REAR WINDOW OPTIONS

Rear visibility is also maximised on X-Series trucks. A large single centre rear window is standard with day cabs, while our optional high-visibility three-window configuration increases the rear window area by 77% over previous legacy models. Optional impact-resistant polycarbonate rear window configurations are available, protecting your truck from road or job site debris.

Optional low trench style cab shown

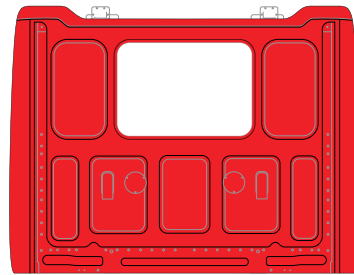

Standard Single Rear Window

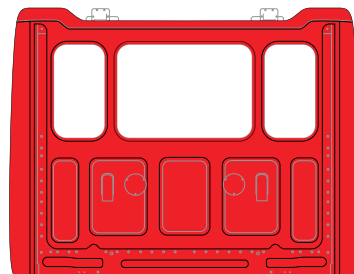

Optional Three-Piece Rear Window

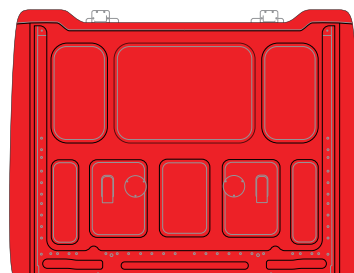

Optional Solid Wall

### INGRESS AND EGRESS

Western Star designed the X-Series with driver safety in mind, which includes getting in and out of the cab. Some of the features to improve ingress and egress safety include:

- > Strategically-located grab points and grab handles for safe and comfortable entry and exit
- > Metal scuff plates that define the entry and make the cab easy to sweep out, keeping it debris-free
- > Highly-visible corrosion-resistant aluminium steps one inch larger than previous models
- > Enhanced tread pattern to allow debris to pass through, giving drivers a confident foothold when climbing in and out of the truck
- > Improved stair step design provides the driver with a confident foothold



# STRONG AND STABLE.

## FUNCTION THAT'S INCREDIBLY TOUGH.



### THE C-BAR MIRROR SYSTEM

Visibility is critical, which is why the C-bar door-mounted mirror arms feature a reduced profile for greater forward visibility for when drivers need to see around them. The door and mirror structure was tuned to avoid mirror vibration and deliver a stable image at all times, regardless of vehicle speed or road surface, while also allowing for a wide 70-degree door-open angle. Plus, this reinforced construction, combined with our breakaway feature, means these mirrors can take a hit and not get damaged. All of which means these mirrors improve safety and your bottom line.

SUPERIOR COMFORT

*An interior that's far from ordinary*

# SUPERIOR COMFORT.

Offering superior comfort, X-Series cabins deliver a highly ergonomic and intuitive driving environment with generous ingress and egress, and sleeper options that include the largest on the Australian market – the 72" Stratosphere walk through integrated sleeper.

**SUPERIOR COMFORT**

*Spacious and ergonomic interior*

# STAY IN COMPLETE CONTROL.

The X-Series dash is designed to allow drivers to keep their hands on the wheel and eyes on the road. In addition to easy-to-read gauges, the instrument cluster features our driver command centre, which provides a wealth of information such as gear selection and gauge readings like oil pressure, as well as fault events and feedback from the Detroit Assurance suite of safety systems.

The ergonomic wrap-around dash not only makes the driver's job easier, it provides a modern look that allows for up to 13 gauges on the dash in addition to the six digital gauges available in the driver command centre. Combined with our integrated steering wheel controls, the X-Series not only helps keep drivers alert, it helps keep their eyes and hands right where they need to be.



**DIGITAL DASH OPTION\***

The optional digital dash provides a high definition 300 mm driver display screen and 254 mm touchscreen infotainment unit that includes Apple Carplay/Android Auto features.

*\*Available on all X-Series models with DT12 transmission only.*



**WRAP-AROUND DASH**

The spacious X-Series interior creates an inviting environment, while the insulation and finish improves both sound levels and temperature control. And the ergonomic design puts control and critical information within reach, making even the toughest jobs more manageable.

**CONTROLS**

Remote mirror and window control switches are within easy reach, located on the door panels for convenience.

**MULTI-FUNCTION STEERING WHEEL**

The steering wheel features integrated controls for cruise control, Bluetooth phone, and driver command centre interaction, allowing drivers to safely keep their focus on the job and the road ahead.

**QUICKFIT DASH ACCESS**

Located on top of the dash near the windshield to easily route wires to power dash-mounted devices.



**HEATING AND COOLING**

The heating and cooling system in our X-Series trucks is designed to deliver superior performance, reliability and serviceability with five face outlets, four floor outlets, and two side window defrost outlets, as well as 10 blower speeds for optimal performance and driver and passenger comfort.



**THE X-SERIES WINDSHIELD**

Our X-Series trucks feature a one-piece, roped-in windshield, which is 28% larger than our legacy vehicle and easy to replace if required.



**CUPHOLDERS**

Three extra-large cupholders are within convenient reach of the driver and designed to hold even the largest beverages.



**SWITCHES**

Rocker-style dash switches are large enough to operate with gloves on, are easy to read with laser-etched graphics and backlighting, and make programming outputs/interlocks and upfit easier than ever thanks to our proprietary CHEC tool.



**TRANSMISSION CONTROL STALK**

For automated manual and automatic transmission shifting and engine braking functions for safer operation.



**PTO CONTROL LOGIC**

When the PTO is engaged, you can view your engine speed presets in the driver command centre and, using the control buttons in the multi-function steering wheel, change engine speeds with the push of a button.

**SUPERIOR COMFORT**

Extensive interior options

# A DESIGN THAT IMPRESSES

Western Star Trucks has always been known for driver comfort and our X-Series trucks take it to another level. Our interior package includes a selection of durable materials and ergonomic features to deliver long-lasting beauty and comfort that makes working behind the wheel productive and enjoyable.

## INTERIOR COLOURS\*



Quarry Grey Charcoal Black Timber Brown

\*Not all colours are compatible with an integrated seat belt.



## CAB TYPES†



### DAY CAB

Available in:  
**47X**  
**48X**



### 36" TRENCH-STYLE LOW ROOF

Available in:  
**47X**  
**48X**



### 36" MID ROOF

Available in:  
**47X**  
**48X**



### 48" MID ROOF

Available in:  
**47X**  
**48X**  
**49X**



### 60" MID ROOF

Available in:  
**48X**  
**49X**



### 72" MID ROOF

Available in:  
**49X**



### 72" STRATOSPHERE HIGH ROOF

Available in:  
**49X**

†Images shown for illustration purposes only and do not show full detail e.g. optional windows, optional roof spoiler and side extenders.

# DESIGNED FOR GREATER COMFORT

## AND PRODUCTIVITY.

X-Series sleepers have numerous features and options that give drivers the customised living and working space they need when they're on the road, ensuring they're alert and engaged behind the wheel. Configuration dependent, some of the amenities include:

- > A comfortable double-bunk option with space-saving telescoping ladder for the 72" sleeper cabin
- > Large sidewall sleeper window insulated for comfort that can be tilted out for venting
- > LED premium ambient overhead sleeper lighting with dimmer provides indirect illumination making activities like reading, updating logs, or computer work easier – 60" and 72" sleeper models only
- > Optional driver's loft with dinette/work table that can be folded flat to allow full bed mattress comfort – 72" sleeper model only



- > Both side access and baggage doors added for easier access and greater storage – 36", 60", and 72" sleeper
- > Reading light to make sleeper tasks easier while saving battery life
- > Bunk storage lip to reduce likelihood of items moving during transit
- > Large passenger- and driver-side storage cabinets – 60" and 72" sleeper models only

- > Spacious wardrobe cabinet with four inches of additional hanging length
- > Conveniently-located microwave cabinet built to accommodate standard appliances
- > Large fridge available in the 72" sleeper with matching cabinetry or the option to supply your own fridge
- > Enhanced HVAC for better climate control in bunk area
- > Rear window option – not available with double bunks



SUPPORT YOU CAN COUNT ON

Extensive parts and service support

# TOUGH TRUCKS.

## BACKED BY EVEN STRONGER SUPPORT.

Trucks are a big investment. That's why we make sure you have the support you need to succeed.

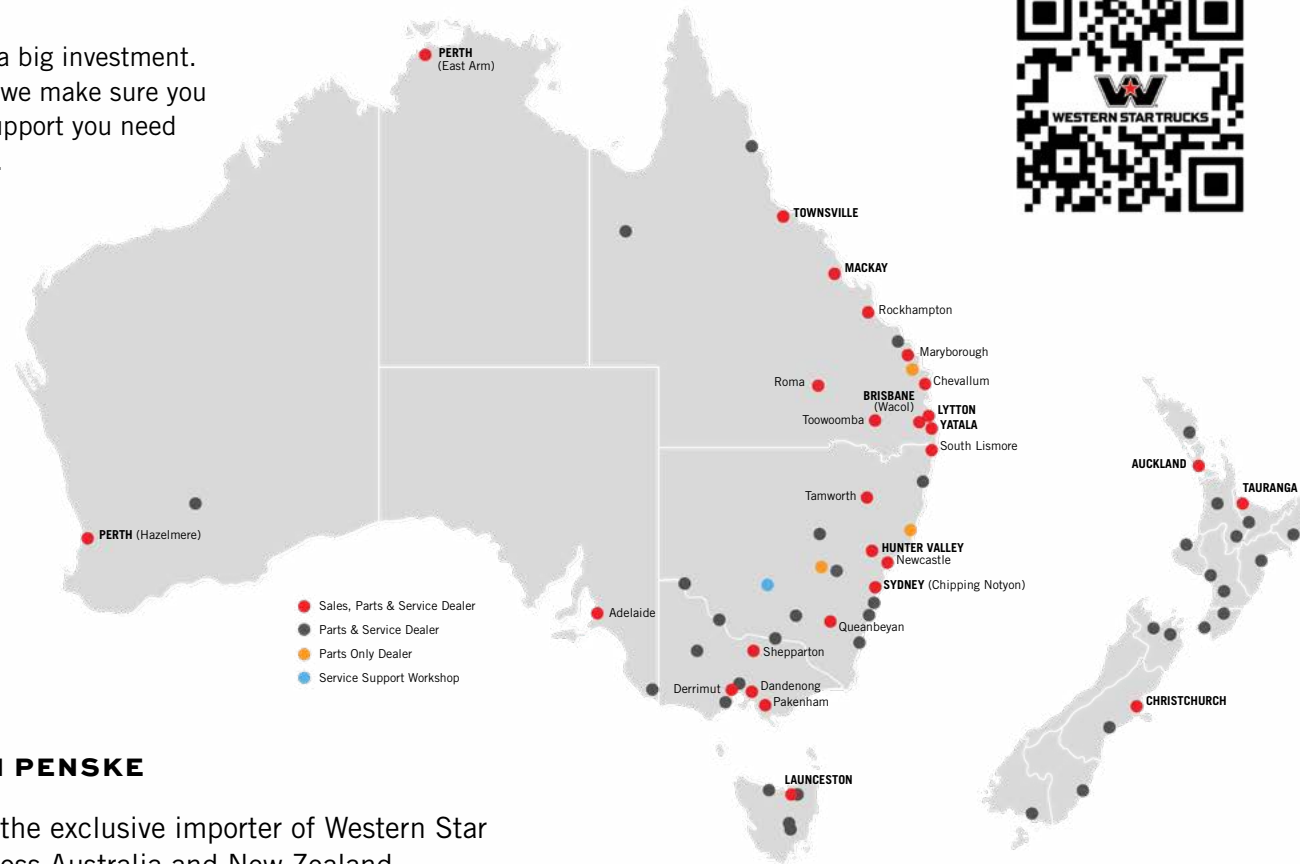

### RELY ON PENSKE

Penske is the exclusive importer of Western Star Trucks across Australia and New Zealand.

Penske Australia and Penske New Zealand are subsidiaries of Penske Automotive Group (PAG), a diversified international transportation services company and one of the world's premier automotive and commercial truck retailers. PAG operates dealerships principally in the United States, the United Kingdom, Canada, Germany, Italy, and Japan, and employs more than 23,000 people globally.

With a network over 60 company-owned and independent dealers across Australia and New Zealand, Penske provides full authorised parts, service and warranty functions.

### PENSKE DISTRIBUTION CENTRE

In addition to our extensive network of dealers across Australia and New Zealand, customers are also fully supported by our Penske Distribution Centre (PDC).

Located in Wacol, QLD, our state-of-the-art PDC comprises a total floor area of 20,000 sq metres and has an inventory of over 1.3 million parts.

Our efficient picking and packing processes ensure we are able to meet high levels of performance and effectiveness, achieving an on-time dispatch of 99.9% and an accuracy rate of 99.9%.

**STAR CHOICE**  
MAINTENANCE

**STAR SILVER**  
MAINTENANCE & DRIVELINE

**STAR GOLD**  
REPAIR & MAINTENANCE

### STAR CARE REPAIR & MAINTENANCE

Star Care offers three tailored levels of support designed to keep your vehicle performing at its best:

- **Star Choice:** Set maintenance only, covers the vehicle for scheduled log book servicing.

- **Star Silver:** Manufacturer's engine warranty, transmission, drive heads and axle housing. Driveline must be taken with service contract (as per Star Choice).

- **Star Gold:** Full R&M package will cover you for complete maintenance and repairs for the life of the contract, bumper to bumper.

With fixed monthly rates, 24/7 Star Assist, and flexible options to suit your business needs, Star Care delivers stress-free trucking and the best possible care for your Star.

### ADVANCED TECHNOLOGY

We invest in technology that can keep your trucks working and working longer. And that goes well beyond technology like Detroit Connect. With Western Star, you get a full suite of uptime management services and technology to get your trucks back working as soon as possible.

Our extensive network of dealers will work with you to get you checked in quickly, diagnosed quickly, and back on the job quickly. At Western Star, even our technology works hard.

### YOU'RE COVERED

Strong support also means having a strong warranty. And Western Star trucks are backed by one of the strongest standard warranties in the business.

Extended coverage plans for your truck chassis are designed to reduce downtime and costly repairs by extending protection for time and mileage above and beyond the factory warranty period.



**STAR ASSIST™**

### 24/7 STAR ASSIST

Under 24/7 STAR ASSIST, the Western Star dealer network, in association with NTI, provides owners and drivers with emergency roadside repairs and assistance, around the clock seven days a week for an entire 24 months from the in-service date of your new Western Star vehicle.

In the event of a breakdown, no matter where you are, 24/7 STAR ASSIST is ready to do whatever we can to get you going.

**1800 247 WSTAR**  
**1800 247 97827**



**FOR THE WESTERN STAR DEALER NEAREST TO YOU,  
VISIT [WESTERNSTAR.COM.AU/DEALERS](http://WESTERNSTAR.COM.AU/DEALERS)**



All information and specifications are correct at the time of printing. Information and specifications are subject to change without notice. Some images are for illustrative purposes only and may not reflect the local product. For current information, please consult your local Western Star Trucks sales professional. February 2026.

